

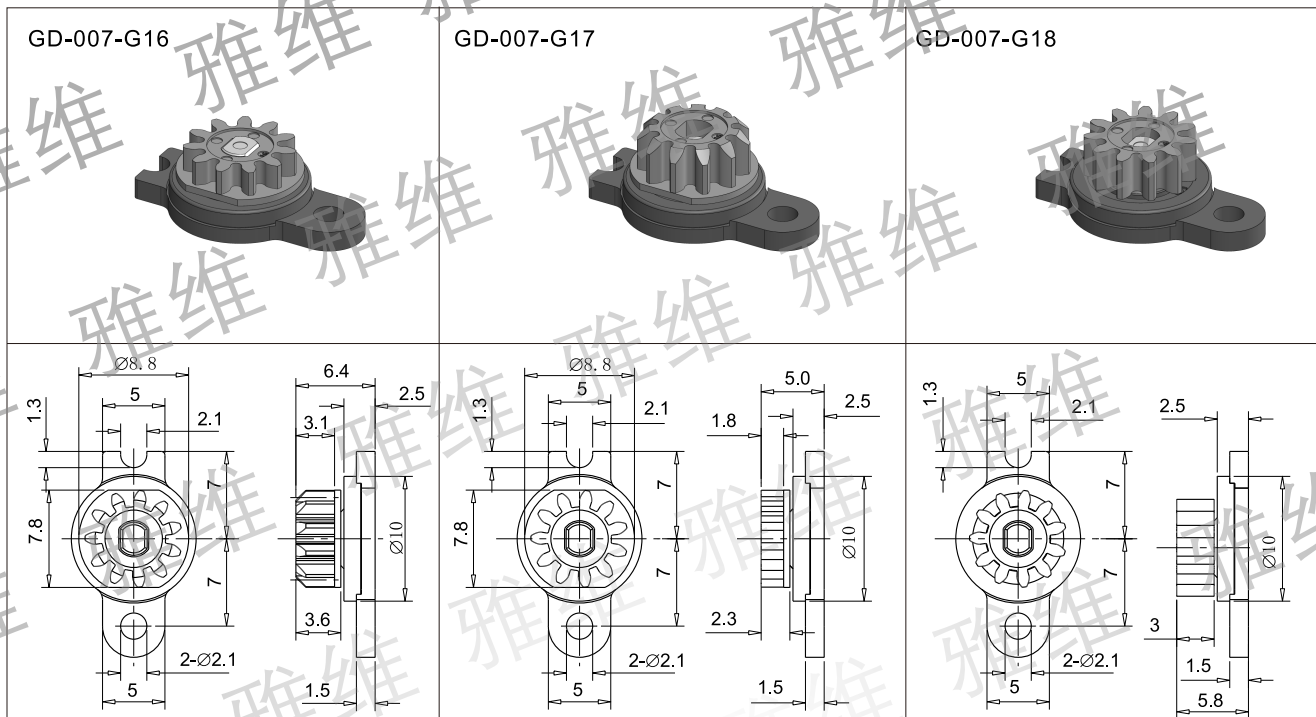

## 规格尺寸 Specification Size



## 齿轮参数 Gear Specification

型号 Part No.	G16	G17	G18
类型 Type	标准平齿轮 Standard Spur Gear		
齿形 Teeth Profile	渐开线齿轮并齿 Involute Full Depth Gear		
模数 Module	0.6	0.6	0.6
压力角 Pressure Angle	20°	20°	20°
齿数 Number of Teeth	11	11	11
基准节圆 Pitch Diameter	Ø6.6	Ø6.6	Ø6.6

## 扭矩类型 Torque Type

型号 Part No.	扭矩 Torque (gf.cm/N.cm)	扭矩方向 Direction
GD-007-G*-10	10±5 / 0.1±0.05	双向 Both Directions
GD-007-G*-15	15±7 / 0.15±0.07	
GD-007-G*-25	25±8 / 0.25±0.08	
GD-007-G*-35	35±10 / 0.35±0.1	
GD-007-G*-50	50±10 / 0.5±0.1	
GD-007-G*-65	65±12 / 0.65±0.12	

## 材料 Materials

名称 Description	材质 Material
底座 Housing	PC/ABS
盖子 Cap	PC/ABS
转轴 Rotor	POM
齿轮 Gear	POM
油 Oil	硅油 Silicone oil

## 备注 Remark

- ① 扭矩数据为20rpm,温度为23°C。  
Standard torque is decided at 20rpm and 23°C
- ② 可以通过更换油的粘度提供特殊扭力定货。  
Within limits different torques can viscosity oil.

## 缓冲器耐久性 Damper Durability

- \*最大使用回转速度 Max. Rotation Speed (rpm) 50
- \*最大使用频率 Max. Cycle Rate (cycles/min) 10
- \*使用温度范围 Operatin Temperature (°C) -30 ~ 80
- \*耐久使用 Durability  
50000次 (常温:23°C) 1循环=正转0.5圈 → 反转0.5圈 (20rpm)  
50000cycles (23°C ambient temperature)  
1 cycle = 0.5 revolutions forward (20rpm) → 0.5 revolutions backward (20rpm)